

Reduced operator's
fatigue in vertical
grinding

Pneumatic Angle Grinder **MYTON**

Model **MLG-70** Lever Type  / Ring Type
for 7" Depressed Center Grinding Wheel

LIGHT COMPACT BODY YET FAST AND EFFICIENT GRINDING!



Model **MLG-70**
Lever Type 



Model **MLG-70**
Ring Type

Features

- Low compact angle head for good accessibility.
- Comfortable smaller diameter grip for maximum control.
- Side handle can be mounted to right or left.
- Spindle lock button makes replacement of depressed center grinding wheel easy.

Applications

Deburring, cleaning and smoothing applications at fabrication shops, foundries, refineries, shipyards, power plants and a variety of other industries.

Pneumatic Angle Grinder

MYTON

Model **MLG-70** Lever Type  / Ring Type
for 7" Depressed Center Grinding Wheel

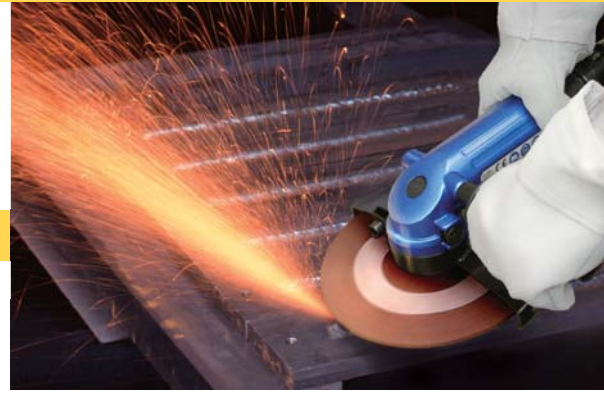

**Spindle lock button
for fast and easy
wheel replacement**

Specifications

Model	MLG-70 Lever Type / Ring Type	
Maximum Operating Pressure	MPa(kgf/cm ²)	0.6 (6)
Air Consumption	m ³ /min	0.75(No load) 1.1(Load)
Rated Speed	min ⁻¹ (rpm)	7,600
Depressed Center Grinding Wheel	mm	180 O.D.
Air Inlet	inch	Rc3/8
Mass (Weight)	kg	2.25

Standard Accessories	
•6mm Hex. Socket Screw Key	1pc.
•10mm Hex. Socket Screw Key	1pc.
•Bushing Rc3/8 x NPT3/8	1pc.
•Handle Ass'y	1set.

Dimensions

unit:mm

Lever Type 

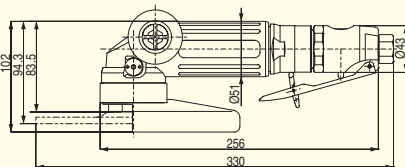
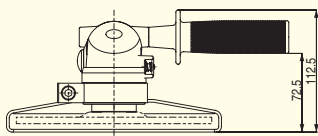
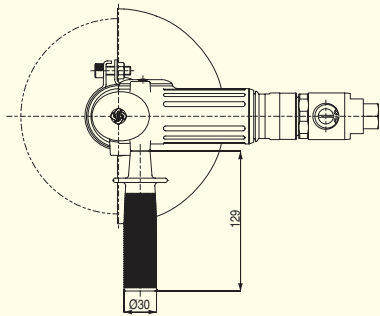

Ring Type

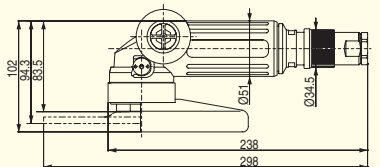
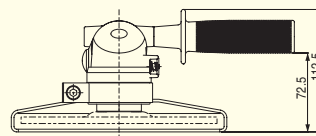
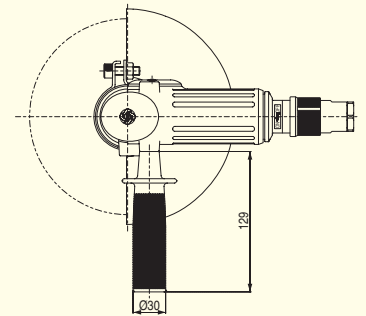

NITTO
NITTO KOHKI CO.,LTD.

Head Office

9-4, Nakaikagami 2-chome,
Ohta-ku, Tokyo 146-8555 Japan
Phone : +81-3-3755-1111 Fax : +81-3-3753-8791

▶ E-mail : overseas@nitto-kohki.co.jp

▶ URL : www.nitto-kohki.co.jp/e

Distributed by



● For environmental conservation, this print is made of the pulp blended with waste paper and printed with soy-based inks.

Printed in Japan 09IA05-1

▶ Specifications and designs are subject to change at any time without notice.