

For Hydraulics

210 Cupla

For hydraulic pressure up to 20.6MPa (210kgf/cm²)

Working pressure



Valve structure



Applicable fluids

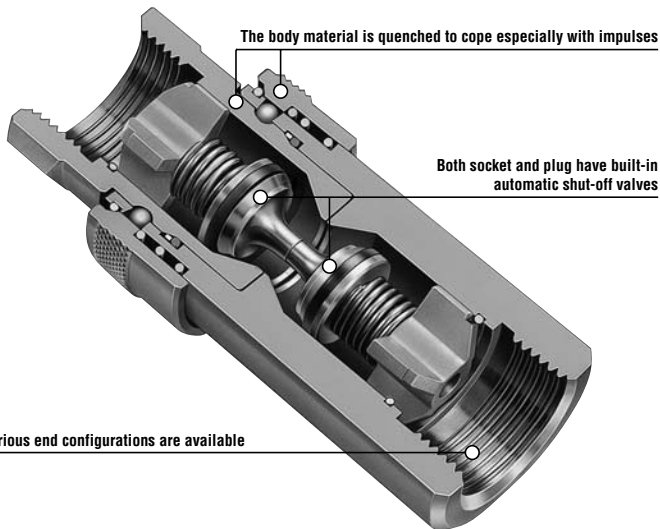
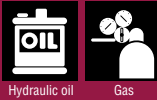

Various end configurations are available

Standard hydraulic Cuplas for general purposes with a working pressure up to 20.6MPa.

Low pressure loss, suitable for hydraulic equipment.

- General purpose hydraulic Cuplas with a working pressure of 20.6MPa(210kgf/cm²).
- Structure is designed to reduce pressure loss to the lowest, and is best for hydraulic applications that need big flow rates.
- Both socket and plug have built-in automatic shut-off valves that prevent fluid outflow when disconnected. Easy to handle.

Specifications

Body material	Special steel (Nickel-plated)			
Size	1/4" • 3/8" • 1/2" • 3/4" • 1"			
Working pressure MPa (kgf/cm ²)	20.6 (210)			
Pressure resistance MPa (kgf/cm ²)	31.0 (316)			
Seal material Working temperature range	Seal material	Mark	Working temperature range	Remarks
	Nitrile rubber	NBR (SG)	-20°C~+80°C	Standard material
	Fluoro rubber	FKM (X-100)	-20°C~+180°C	Available on request

Max. Tightening Torque

N·m (kgf·cm)

Size	1/4"	3/8"	1/2"	3/4"	1"
Torque	28 (286)	45 (459)	90 (918)	100 (1020)	180 (1836)

Flow Direction

Fluid may flow in either direction from plug or from socket side when coupled.

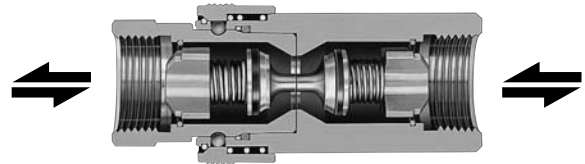

Interchangeability

Different sizes are not interchangeable.

Min. Cross-Sectional Area

(mm²)

Model	210-2SP	210-3SP	210-4SP	210-6SP	210-8SP
Min. Cross-Sectional Area	24.5	42.8	77.4	146.5	235.6

Suitability for Vacuum

1.3Pa (1 x 10⁻²mmHg)

Socket only	Plug only	When connected
—	—	Operational

Admixture of Air on Connection

(mℓ)

Model	210-2SP	210-3SP	210-4SP	210-6SP	210-8SP
Volume of air	0.85	1.02	2.63	8.83	16.04

Flow Rate – Pressure Loss Characteristics

[Test conditions] •Fluid : Hydraulic oil •Temperature : 30°C ± 5°C
•Fluid viscosity : 32 x 10⁻⁶m²/s •Density : 0.87 x 10³kg/m³

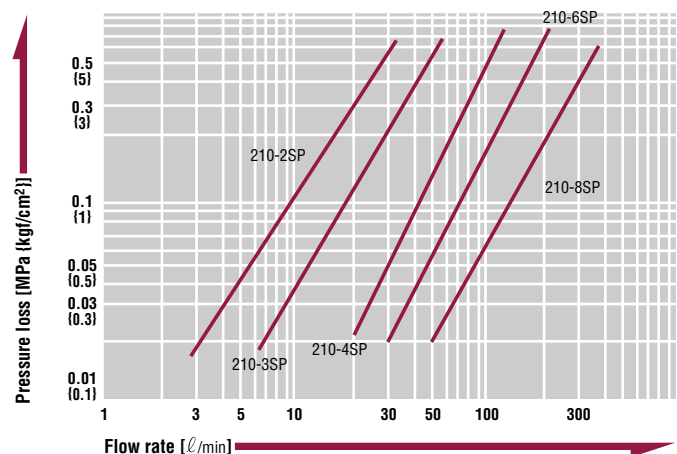

Models and Dimensions

Plug Female thread

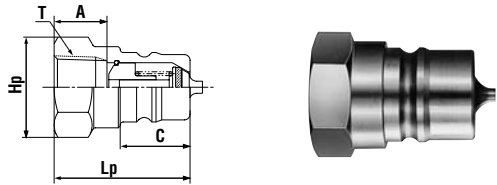

Model	Application	Mass (g)	Dimensions (mm)				
			Lp	C	Hp (WAF)	A	T
210-2P	R 1/4	39	33	18	Hex.19	13	Rc 1/4
210-3P	R 3/8	57	36	18.5	Hex.23	14	R c3/8
210-4P	R 1/2	90	42.5	24	Hex.27	15.5	Rc 1/2
210-6P	R 3/4	195	51	28	Hex.35	18	R c3/4
210-8P	R 1	293	61	35	Hex.41	19.5	Rc 1

Socket Female thread

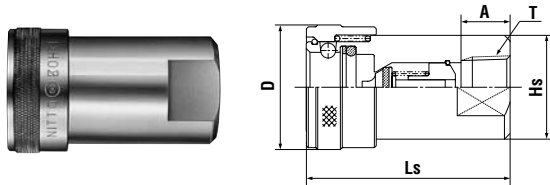

Model	Application	Mass (g)	Dimensions (mm)				
			Ls	øD	HS (WAF)	A	T
210-2S	R 1/4	158	50.5	30	Two flats 22 x ø25	13	Rc 1/4
210-3S	R 3/8	193	54	33	Two flats 23 x ø27.5	13	Rc 3/8
210-4S	R 1/2	330	65	39	Two flats 29 x ø34	15.5	Rc 1/2
210-6S	R 3/4	566	78.5	48	Two flats 35 x ø41.3	18	Rc 3/4
210-8S	R 1	861	95	55	Two flats 41 x ø47.8	19.5	Rc 1

Application example



Hydraulic control equipment



Construction machinery