

# Accessories for Cuplas

## Index



	Product Name	Page
<b>A</b>	Accessories for Air Lines	124
	Accessories for O-ring Maintenance	125
<b>D</b>	Dip Mold Cap	123
	Dust Cap	124
<b>P</b>	Protection Cover	124
	Purge Adapter	125
<b>R</b>	Residual Pressure Release Jig	125
<b>S</b>	Safety Cap	123
	Sleeve Cover	124
	Sleeve Stopper	124

## Dip Mold Cap

Dust caps for Hi Cupla, SP Cupla Type A, TSP Cupla, and Hydraulic Cupla



- PVC Dust Caps produced by dip molding are available for Hi Cuplas, SP Cuplas Type A, TSP Cuplas, and Hydraulic Cuplas. Dust Caps prevent dust from getting inside the fluid line and protects the sealability and life of the O-ring.

	Part number	Cap for Hi Cupla	Sales unit		Part number	Cap for SP Cupla Type A	Sales unit		Part number	Cap for TSP Cupla	Sales unit		Part number	Cap for HSP Cupla	Sales unit	
Socket	CA96462	For 20 type	1	Socket	CA96462	For 1S-A	1	Socket	CA96542	For 1TS	1	Socket	CA96463	For 2HS	1	
		For 30 type	1		CA96463	For 2S-A	1		CA96462	For 2TS	1		CA96476	For 3HS	1	
		For 40 type	1		CA96464	For 3S-A	1		CA96463	For 3TS	1		CA96477	For 4HS	1	
		For 600 type	1		CA96465	For 4S-A	1		CA96464	For 4TS	1		CA96477	For 6HS	1	
	CA96464	For 400 type	1		CA96466	For 6S-A	1		CA96465	For 6TS	1		CA96478	For 6HHS	1	
		For 600 type	1		CA96467	For 8S-A	1		CA96479	For 8TS	1		CA96479	For 8HS	1	
		For 800 type	1		CA96468	For 10S-A	1		CA96553	For 10TS	1		CA96481	For 10HS	1	
					CA96449	For 12S-A	1		CA96555	For 12TS	1		CA96481	For 12HS	1	
Plug	CA96453	For 20 type	1	Plug	CA96470	For 16S-A	1	Plug	CA96557	For 16TS	1	Plug	CA96482	For 16HS	1	
		For 30 type	1		CA96453	For 1P-A	1		CA96541	For 1TP	1		CA96454	For 2HP	1	
		For 40 type	1		CA96454	For 2P-A	1		CA96453	For 2TP	1		CA96455	For 3HP	1	
		For 600 type	1		CA96455	For 3P-A	1		CA96454	For 3TP	1		CA96456	For 4HP	1	
	CA96455	For 400 type	1		CA96456	For 4P-A	1		CA96455	For 4TP	1		CA96456	For 6HP	1	
		For 600 type	1		CA96457	For 6P-A	1		CA96456	For 6TP	1		CA96471	For 6HHP	1	
		For 800 type	1		CA96458	For 8P-A	1		CA96551	For 8TP	1		CA96472	For 8HP	1	
					CA96459	For 10P-A	1		CA96552	For 10TP	1		CA96473	For 10HP	1	
		CA96460	For 12P-A	1	CA96459	For 12TP	1	CA96473	For 12HP	1						
		CA96461	For 16P-A	1	CA96556	For 16TP	1	CA96475	For 16HP	1						
Socket	CA96463	For 210-2S	1	Socket	CB17082	For 280-2S	1	Socket	CA81551	For F35/350-3S	1	Socket	CB00614	For 700R-3S	1	
	CA96476	For 210-3S	1		CA96476	For 280-3S	1		CA81555	For F35/350-4S	1		CA82644	For 700R-4S	1	
	CA81555	For 210-4S	1		CA81555	For 280-4S	1		CA97213	For F35/350-6S	1		Plug	CA83164	For 700R-3P	1
	CA96478	For 210-6S	1		CA96466	For 280-6S	1		CA80401	For F35/350-8S	1			CA82643	For 700R-4P	1
	CA96466	For 210-8S	1		CA96466	For 280-8S	1									
Plug	CA96454	For 210-2P	1	Plug	CA96453	For 280-2P	1	Plug	CA81553	For F35/350-3P	1					
	CA96455	For 210-3P	1		CA96455	For 280-3P	1		CA81557	For F35/350-4P	1					
	CA82643	For 210-4P	1		CA82643	For 280-4P	1		CA97215	For F35/350-6P	1					
	CA96471	For 210-6P	1		CA96471	For 280-6P	1		CA80402	For F35/350-8P	1					
	CA96551	For 210-8P	1		CA96551	For 280-8P	1									

## Safety Cap

Metal caps for Hi Cupla Series, SP Cupla Type A, TSP Cupla and Hydraulic Cupla  
(Semi-standard)

- Metal Cap equipped with dust-proof and leak prevention function.
- Caps with metal material corresponding to that of Cupla body are available.

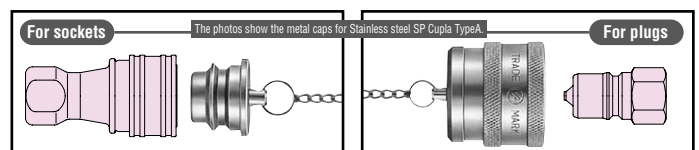

Model	Applicable Cuplas	Sales unit
<p>Model name of Safety Cap is stated in the following manner.</p> <p><b>Model= Cupla Model (normal Cupla) + SD (safety cap)</b></p>	<p>Example: "2S-A-SD" identifies a safety cap for SP Cupla Type A Model 2S-A.</p> <p>Sockets and plugs for Hi Cupla, SP Cupla Type A, TSP Cupla, HSP Cupla, 210 Cupla, S210 Cupla, 350 Cupla, 450B Cupla and SP-V Cupla</p>	1pc.

When ordering, please indicate Model Name or part number. Semi standard items: As these items are not always in stock, delivery time is subject to confirmation.

# Sleeve Cover

Plastic cover for Hi Cupla Series (5pcs.per package)

- Easier sliding operation is achieved by attaching an additional plastic cover over the socket sleeve of Hi Cupla Series.
- Plastic covers reduce the risk of damage if the Cupla strikes other components or products.
- Sleeve covers in various colors allow for easier identification of various air lines.



Attached Sleeve Cover

The sleeve cover cannot be used together with the dust cap or dip mold cap.

Part number	Model	Color	Applicable Cuplas	Sales unit	Material
CB23588	SLC-HI-R	Red	For Hi Cupla Series Sockets  Note: Sleeve covers cannot be attached to sockets for the Full-Blow Cupla, 400/600/800 Hi Cupla, Hi Cupla Ace, Stainless Hi Cupla and Brass Hi Cupla.	5	Thermoplastic elastomer (TPE)
CB23590	SLC-HI-B	Blue		5	
CB23589	SLC-HI-Y	Yellow		5	
CB23591	SLC-HI-W	White		5	
CB23587	SLC-HI-K	Black		5	

# Protection Cover

Plastic Cover for Nut Cupla and Full-Blow Cupla Nut Type (Semitransparent)

- For Nut Cupla and Full-Blow Cupla Nut Type.
- Protection cover wraps up the whole Cupla to absorb impacts and to reduce the risk of damage if the Cupla accidentally strikes other components or products.
- Protection covers can be cut to fit the hose diameter which the Cupla is connected to.
- Can be attached to either the socket or the plug, and can be used as a dust cap.

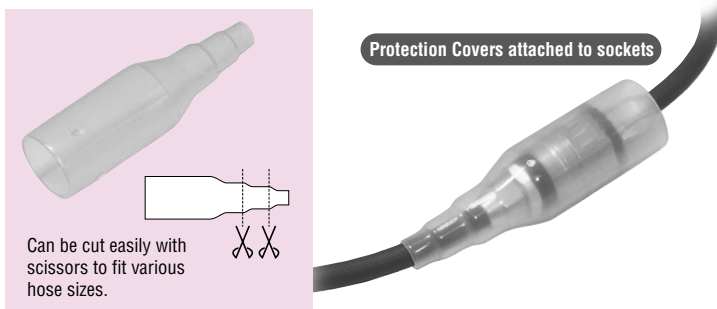

Protection Covers attached to sockets

Can be cut easily with scissors to fit various hose sizes.

Part number	Model	Applicable Cuplas	Sales unit	Material
CB23784	SOC-HI	Can be attached to Nut Cupla socket or plug (SN type & PN type) and the Full-Blow Cupla socket (SN Type).	1	Polyvinyl chloride (PVC)

# Dust Cap

Plastic Cap for Hi Cupla Series

- Dust caps prevent dust from getting inside Cuplas.



For sockets

Dust covers cannot be used together with sleeve covers.

Part number	Model	Applicable Cuplas	Sales unit	Material
CQ12434	20S-D	Sockets for 20/30/40 type Hi Cupla Series  Note: Dust caps cannot be attached to the sockets for Full-Blow Cupla, 400/600/800 type of Hi Cupla and Hi Cupla Ace.	1	Polyvinyl chloride (PVC)

# Accessories for Air Lines

Air Lines for Hi Cupla Series

- Connects directly to 20/30/40 type Hi Cupla sockets.
- Convenient to control drainage and pressure in air lines.



Drain Cock

Pressure Gauge

Part number	Model	Cuplas that accessories can be mounted on	Sales unit	Description
CB23625	DC-30PF	Hi Cupla sockets	1	Drain Cock
CB11253	PG-10P	Hi Cupla sockets	1	Pressure Gauge

# Sleeve Stopper

Sleeve Stopper for SP Cupla Type A

- Sleeve stopper exclusively for SP Cupla Type A sockets. Attaching the sleeve stopper after connection of socket and plug locks the sleeve of the socket and prevents unexpected disconnection.

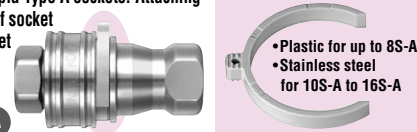

Attached to SP Cupla Type A

- Plastic for up to 8S-A
- Stainless steel for 10S-A to 16S-A

Part number	Model	Applicable Cuplas	Sales unit	Material	Part number	Model	Applicable Cuplas	Sales unit	Material
Socket	CB24350	SP Cupla type A sockets	10	Engineering plastics (POM)	Socket	CB26456	SP Cupla type A sockets	1	SUS 304
	CB24351		10			CB26457		1	
	CB24352		10			CB26458		1	
	CB24353		10						
	CB24354		10						
	CB24355		10						

When ordering, please indicate Model Name or part number.

# Accessories for O-ring Maintenance

Jigs & grease for replacement of O-rings for SP Cupla Type A, TSP Cupla and HSP Cupla

- Quality of seal materials plays an important role in maintaining the performance of a Cupla. O-rings or seal materials of SP Cupla, TSP Cupla and HSP Cupla are designed to be replaceable. Please be certain to choose the correct and genuine Nitto kohki O-ring in order to maintain the performance of Cuplas.

### Jig for O-ring replacement

- Model: PMJ-1 (Small)**  
(Part.No.CB23687)  
• Sales unit: 1pc.
- Model: PMJ-2 (Large)**  
(Part.No.CB23688)  
• Sales unit: 1pc.

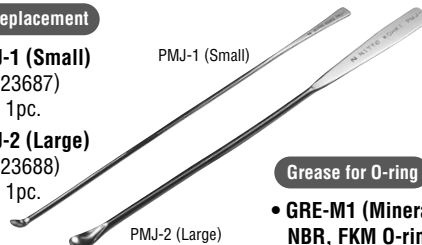

### Grease for O-ring

- GRE-M1 (Mineral oil) for NBR, FKM O-ring or packing**  
(Part.No.CB23701)  
• Sales unit: 1pc.

### Grease for O-ring

- GRE-S1 (Silicon oil) for NBR, FKM, and EPDM O-ring or packing**  
(Part.No.CB23702)  
• Sales unit: 1pc.



5ml container



O-ring for SP Cupla Type A	Part number			Sales unit
	NBR	FKM	EPDM	
For 1S-A	CP01314	CP00907	CP03270	1
For 2S-A	CP00927	CP00928	CP03333	1
For 3S-A	CP00955	CP00956	CP03276	1
For 4S-A	CP00978	CP00979	CP03283	1
For 6S-A	CP01003	CP01004	CP03292	1
For 8S-A	CP01029	CP01030	CP03298	1
For 10S-A	CP00398	CP01053	CP07179	1
For 12S-A	CP01076	CP01077	CP03902	1
For 16S-A	CP01099	CP01100	CP06953	1

O-ring for TSP Cupla	Part number			Sales unit
	NBR	FKM	EPDM	
For 1TS	CP03987	CP04984	CP09795	1
For 2TS	CP01314	CP00907	CP03270	1
For 3TS	CP00927	CP00928	CP03333	1
For 4TS	CP00955	CP00956	CP03276	1
For 6TS	CP00978	CP00979	CP03283	1
For 8TS	CP00387	CP01258	CP04923	1
For 10TS	CP01273	CP01274	CP09221	1
For 12TS	CP00398	CP01053	CP07179	1
For 16TS	CP01304	CP01305	CP09794	1

O-ring for HSP Cupla	Part number		Sales unit
	NBR	FKM	
For 2HS	CP01185	CP02215	1
For 3HS	CP01194	CP03335	1
For 4HS	CP00294	CP02093	1
For 6HS	CP00294	CP02093	1
For 66HS	CP09658	CP25937	1
For 8HS	TP00293	CP01179	1
For 10HS	CP01516	CP03371	1
For 12HS	CP01516	CP03371	1
For 16HS	CP03035	CP03453	1

Backup ring for HSP Cupla	Part number	Sales unit
	PTFE	
For 2HS	CP01186	1
For 3HS	CP01195	1
For 4HS	CP01203	1
For 6HS	CP01203	1
For 66HS	CP09659	1
For 8HS	CP01211	1
For 10HS	CP01517	1
For 12HS	CP01517	1
For 16HS	CP03036	1

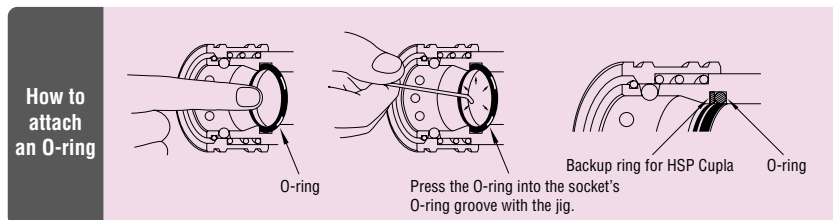
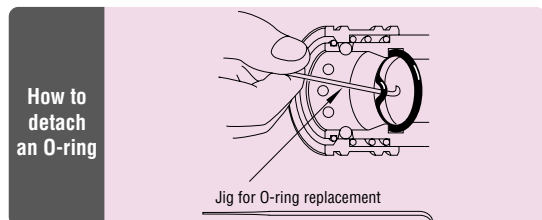

# Residual Pressure Release Jig

Residual Pressure Release Metal Jig

- Residual pressure within socket or plug can be released easily just by turning the handle.
- Residual pressure release jigs are available in two types; socket type for use with plugs and plug type for use with sockets.
- Connecting to sockets or plugs is the same as connecting normal Cuplas.

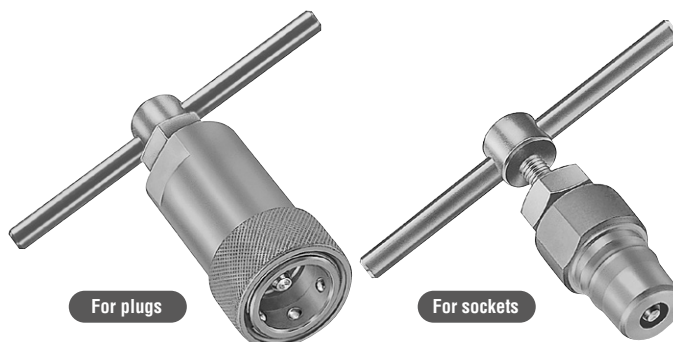

The photos show the jigs for HSP Cupla.

Model	Attachable Cuplas	Sales unit
The model name is to be defined in the following manner. <b>Z N</b> – Type of Cupla to be attached Residual pressure release jig	Sockets and plugs for SP Cupla Type A, HSP Cupla, 210 Cupla, S210 Cupla, 280 Cupla and 350 Cupla	1pc.
Example: For the Cupla model 350-3S, the jig name would be <b>ZN-350-3S</b>		

# Purge Adapter

Metal Purge Adapter for hydraulic lines (Semi-standard)

- Can be attached to hydraulic lines to purge residual pressure effectively.

Model	PAD-2 (Part No.CB19855)
Applicable fluid	Hydraulic oil
Material	Steel (With autocatalytic nickel-phosphorus coating)
Working pressure	MPa(kg/cm <sup>2</sup> ) 35.0 (357)
Pressure resistance	MPa(kg/cm <sup>2</sup> ) 52.5 (536)
Working temperature range	-5°C ~ +80
Application	Rc 1/4

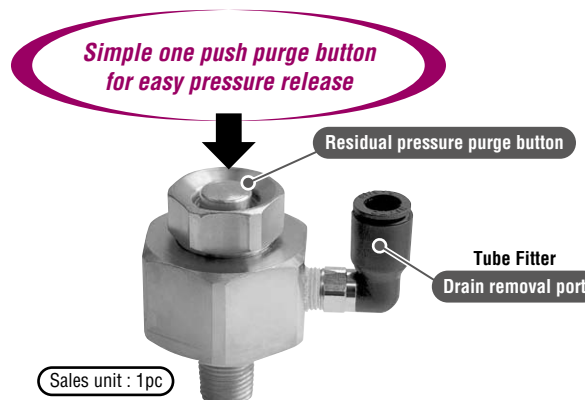

When ordering, please indicate Model Name or part number. Semi standard items: As these items are not always in stock, delivery time is subject to confirmation.