

KUKEN Product Maintenance Standards		SPEC.No.
		Enacted on:1-11-1990
		Issued on:
Symptom of malfunction / Checking Point		Ref Page
No motor rotates	(1) <u>When the anvil does not rotate by hand, the clutch unit is damaged.</u> Remove the bolts tightening the clutch case and check the clutch unit.	P-3
	(2) <u>When the anvil rotates by hand, the motor unit is failing.</u> Remove the bolts connecting the clutch case-motor case and handle-motor case, and check the motor unit.	P-2
Motor rotates, but no impact is given	(1) <u>The clutch unit is damaged.</u> Remove the bolts tightening the clutch case and motor case, and check the clutch unit.	P-3
Motor keeps on rotating	(1) <u>There occurs failure near the air start/stop valve(F valve) in the handle unit and start lever(Type GL).</u> Remove the bolts tightening the handle and motor case, and check the F valve and F lever unit(Both pistol and GL types). Remove the screw sleeve to check for internal parts.	P-3
Insufficient tightening torque	(1) <u>The impact sound is abnormal: a slip sound is heard. The clutch parts are worn.</u> Remove the bolts which tighten the clutch case and motor case, and check the clutch unit.	P-3
	(2) <u>The motor does not rotate powerfully. The start lever pushing allowance is insufficient. (8mm or more is required.)</u> Replace the worn parts of the start lever ,pin & F rod. <u>The motor parts are worn or the unit is loose.</u> Remove the bolts which tighten the clutch case-motor case and handle-motor case, and check the motor unit.	P-3
Impact stops halfway	(1) <u>When the clutch unit is abnormal: Lubrication is insufficient or the cam is worn.</u> Remove the bolts which tighten the clutch case and motor case, and check the clutch unit.	F-3
	(2) <u>When the motor unit is abnormal: The blade is worn.</u> Remove the bolts which tighten the clutch case-motor case and handle-motor case, and check motor unit.	P-2
When no abnormality is found, but insufficient power was pointed out by customer.	(1) <u>The wrench is used for tightening operation in which its capacity is exceeded.</u> Recommend one class higher machine. (2) <u>Air is reduced since the joint parts, such as a quick coupler, are worn. Recommend that the worn parts be replaced.</u> (3) <u>Air is reduced due to impact wrench exhaust unit and air joint freezing.</u> Recommend air compressor water draining. It is more preferable to use the filter and oiler together	

KUKEN PRODUCT Maintenance Standards

SPEC NO.

Type N Impact Wrench
Operating Limit Size (1)

Enacted on:

Issued on:

Profile Feature

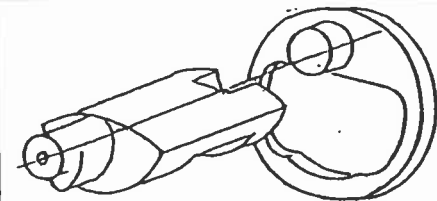
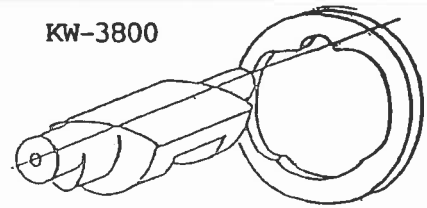
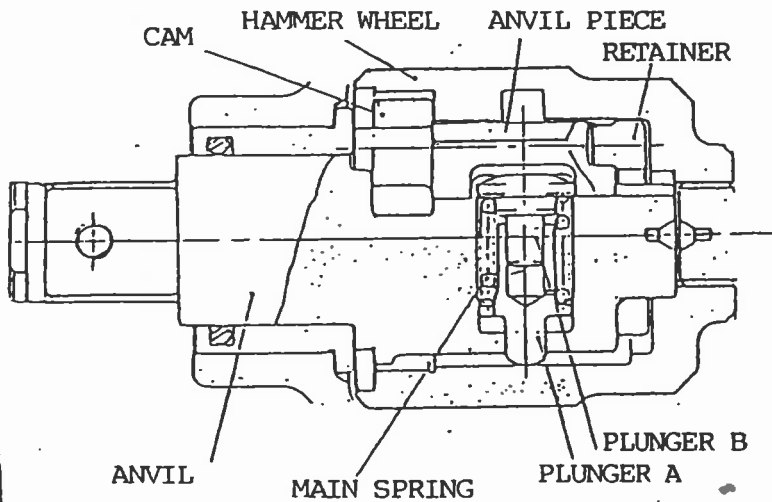

KW-1600, 2000, 2500,
4500, 5000,

HAMMER WHEEL

Simple re-usability check method:
Replacement is required if a
clearance exists when the outer
circumferential grinding finish
part of anvil piece is pressed.

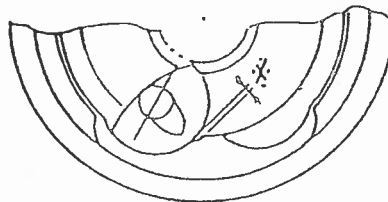
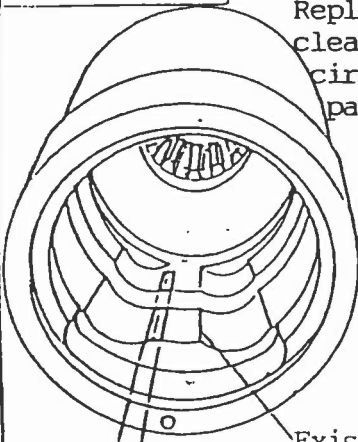

Judgement by calipers
Existence of sharp part(Reusable)

Replacement Standards

TYPE	WIDTH
KW-1600	1.0Min.
2000	1.0Min.
2500	1.0Min.
3800	1.5Min.
4500	1.5Min.
5000	1.5Min.

ANVIL PIECE

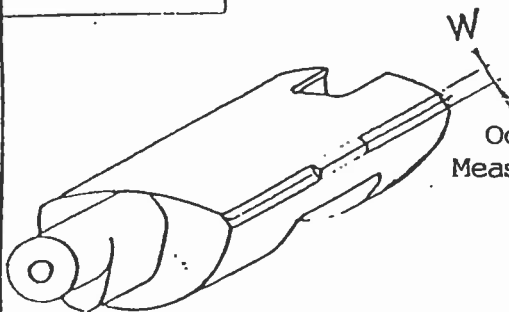

Occurring on the plane
Measure with calipers

Replacement Standards

TYPE	WIDTH
KW-1600	0.7Min.
2000	0.7Min.
2500	0.7Min.
3800	1.0Min.
4500	1.0Min.
5000	1.0Min.

	KUKEN Product Maintenance Standards	SPEC NO.
	Type N Impact Wrench	Enacted on:
	Handle and clutch Units: Repair & Check Procedure	Issued on:

- Faults at handle unit:
- (1) Motor goes on rotating.
 - (2) Start lever does not move smoothly.
 - (3) Output control is impossible.
 - (4) Clockwise/counterclockwise rotation switching lever is loose.
 - (5) Insufficient output.
 - (6) Air leakage.

Handle Parts Checking Items	Countermeasure
(1) Start lever-----Wear	Replace
-----Lever stop pin hole deformed	Replace
(2) F rod -----Wear (Outer circumference and contact part with start lever)	Correct or Replace
(3) F valve -----Deformation (urethane ball)	Replace
(4) Start lever stopper pin-----Wear	Replace
(5) F spring -----Break	Replace
(6) R valve (Regulator)-----Deformation at ball knock at part	Correct or Replace
(7) Each O-ring-----Air leakage caused by wear and breakage	Replace (Apply grease on the surface)

- Faults at Clutch Unit:
- (1) Faulty impact (Hand-up, slip impact, no impact)
 - (2) Poor lubrication (Low grease level, excessive grease, lower grease viscosity)
 - (3) Grease leakage
 - (4) Loose case bushing

Clutch Parts Checking Procedure:	Countermeasure
(1) Cam-----Wear or damage	
(2) Anvil-----Wear or damage	
(3) Anvil piece-----Wear or damage	Correct or replace
(4) Hammer Wheel-----Wear or damage	(Refer to the following when checking)
(5) Plungers A,B-----Wear	
(6) Main Spring-----Permanent set in fatigue or damage	Type N Impact Wrench Clutch Parts
(7) Washer-----Wear	Operating limit size(1)(2)
(8) Retainer-----Damage	New/Old shape comparison Table
(9) Clutch case c.p.-----Deformation	Correct or replace
-----Loose case bushing	Correct or replace
-----Grease leakage(O-ring)	Replace O-ring
(10) Each O-ring-----Wear or breakage	Replace

	KUEKN PRODUCT Maintenance Standards	SPEC NO.
	Type N Impact Wrench Operating Limit Size (2)	Enacted on:
		Issued on:

Main Spring

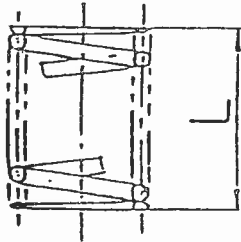

- (1) Replace the spring if the end turn is damaged.
- (2) When replacing the anvil piece with a new one, also replace the main spring at the same time.

Type	New Spring(L)	Operating Limit (L)
KW-1600	13.9	13.5
2000	19.2	18.8
2500	22.1	21.7
3800	26.2	25.7
4500	33.6	33.1
5000	36.4	35.9

Plunger A

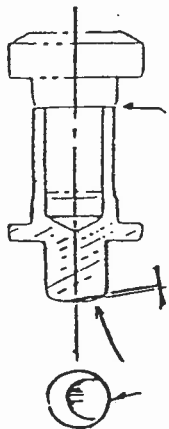

- ① Replace the plunger with a new one if the wear flat at the edge sliding part reaches the shaft outer circumference.
- ②

When replacing the parts, check that the end face of each plunger comes into contact.

Wear flaw

Plunger B

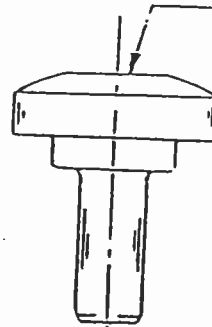

Flat Part

Replace the plunger if the flat part becomes spherical due to wear.

Cam

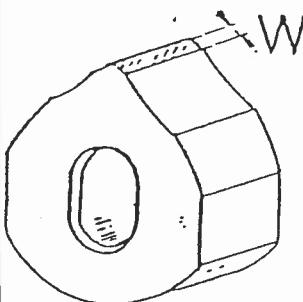



W: Measure the width on the plane due to wear with calipers.

Type	Width
KW-1600	0.7Min
2000	1.0Min
2500	1.0Min
3800	1.5Min
4500	1.8Min
5000	2.0Min

Anvil

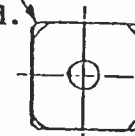
- Anvil replacement precautions:
- (1) With the anvil piece set, it should oscillate smoothly to the right and left.
 - (2) For the plunger insertion hole, check that plunger A, B move smoothly.
- Repair Precautions: Recommend that GL type whole corners which are sharp as shown below be replaced.

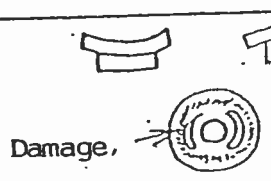
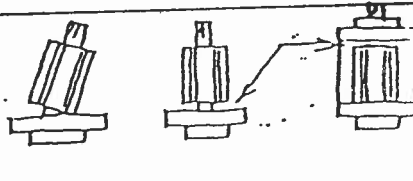
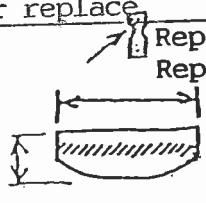

KUKEN Product Maintenance Standards		SPEC NO.
Type N Impact Wrench Motor Unit: Repair and Checking Procedure		Enacted on.
		Issued on.
<p>Faults at motor unit:</p> <ol style="list-style-type: none"> (1) Rotor and end plate seizure (2) Broken rotor spline shaft (3) Blade damage (4) Clogged incoming air path (5) Rusting (6) Ingress of foreign matter into motor (7) Misassembly (For example, failure to insert the blade and incorrect positioning of cylinder and end plate.) 		
Motor Parts Checking Items	Countermeasure	
(1) End plate	<ul style="list-style-type: none"> -Poor flatness -Seizure with rotor -Rusting 	 <p>Damage,</p> <p>Correct or replace Correct or replace Replace</p>
(2) Rotor	<ul style="list-style-type: none"> -Poor setting -Spline shaft broken -Rusting -Shell length is too short (Due to repeated repair) 	 <p>Re-set Replace Correct or Replace Replace</p>
(3) Cylinder	<ul style="list-style-type: none"> -Interior wear and damage -Entire length is too short -Rusting 	<p>Correct or replace Replace</p> <p>Correct or replace</p>
(4) Blade	<ul style="list-style-type: none"> -Wear(Side surface) -Faulty size -White blade(Contraction by overheat) -Brown blade(Expansion by moisture and overheat) -Damage -Failure to insert -Abnormal noise("boon" occurs) 	 <p>Replace Replace</p> <p>Replace</p>
(5) Motor Case	<ul style="list-style-type: none"> -Clogged exhaust hole:Due to ingress of foreign matter -Collapse caused by external impact -Clogged sound insulation material -Faulty size(Excessive inside diameter by repeated disassembly) 	 <p>Remove Correct or replace Remove</p> <p>Replace</p>
(6) Bearing	<ul style="list-style-type: none"> -Damage wear -Rusting 	<p>Replace Replace</p>
(7) Motor Packing	<ul style="list-style-type: none"> -Air leakage caused by break and shrinkage 	<p>Replace</p>



(株) 空研 製品保守基準
 KUKEN Co., Ltd. Repair Limits
 インパクトレンチ (シリンダ)
 IMPACT WRENCH (CYLINDER)

制定日

1998/9/30

改訂日

N型 (N-TYPE)

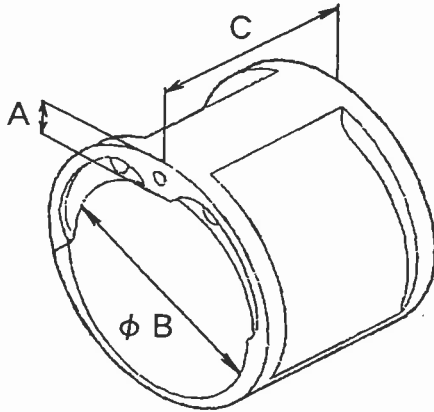

NOTE

1.よく洗浄して注意深く確認してください。

Make sure that any deformation is not observed.

2.接触する部品の摩耗にも注意を払ってください。

Keep your attention to connected parts are worn away.

コードNo. CODE No.	基本機種 MOTHER MODEL	基準寸法 STANDARD DIMENSION		限界 REPAIR LIMIT	型式 MODEL
	KW-089	A	7	6.985	KW-1600P
		B	35	—	
		C	40	39.990	
	KW-141	A	9	8.965	KW-2000P
		B	45	—	
		C	42	41.990	
	KW-201	A	10	9.985	KW-2500P
		B	47.5	—	
		C	52	51.990	
	KW-203	A	11.5	11.480	KW-2800P
		B	62	—	
		C	57	56.990	
	KW-390	A	14.5	14.480	KW-4500G
		B	72.8	—	
		C	55	54.990	
	KW-401	A	15	14.980	KW-5000G
		B	81.4	—	
		C	75	74.990	

(単位 : mm)

The unit size by mm.



(株) 空 研 製品保守基準
 KUKEN Co., Ltd. Repair Limits
 インパクトレンチ (ロータ)
 IMPACT WRENCH (ROTOR)

制定日

1998/9/30

改訂日

N型 (N-TYPE)

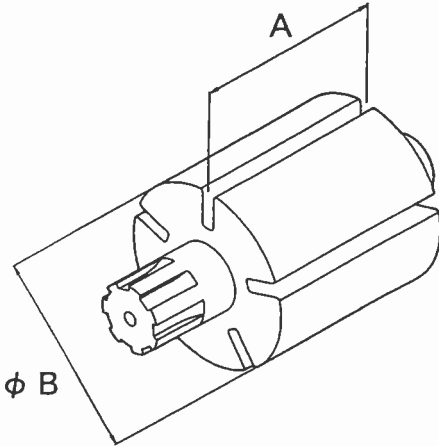

NOTE

1.よく洗浄して注意深く確認してください。

Make sure that any deformation is not observed.

2.接触する部品の摩耗にも注意を払ってください。

Keep your attention to connected parts are worn away.

コードNo. CODE No.	基本機種 MOTHER MODEL	基準寸法 STANDARD DIMENSION		限界 REPAIR LIMIT	型式 MODEL
	N-160	A	40	39.935	KW-1600P
		B	30	29.940	
	N-200	A	42	41.935	KW-2000P
		B	38	37.940	
	N-250	A	52	51.925	KW-2500P
		B	40	39.940	
	N-280	A	57	56.925	KW-2800P
		B	53	52.930	
	N-380	A	57	56.925	KW-3800G
		B	53	52.930	KW-3800P
	N-450	A	55	54.925	KW-4500G
		B	62	61.930	KW-4500P
	N-501	A	75	74.925	KW-5000G
		B	70	69.930	

(単位 : mm)

The unit size by mm:



(株)空研 製品保守基準
 KUKEN Co., Ltd. Repair Limits
 インパクトレンチ (上エンドプレート)
 IMPACT WRENCH (REAR PLATE)

制定日

1998/9/30

改訂日

N型 (N-TYPE)

NOTE

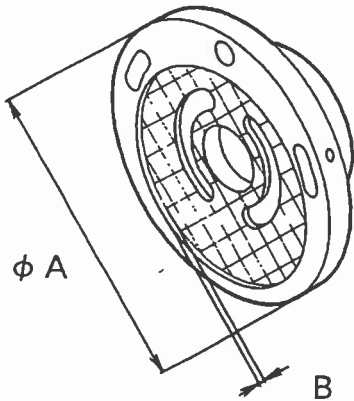

1.よく洗浄して注意深く確認して下さい

Make sure that any deformation is not observed.

2. B寸法が0.03mmを越えた場合、上下エンドプレートを交換して下さい

Please replace the front & rear plate, in case of total abrasion at "B" are more than 0.03mm.

3. 接触する部品の摩耗にも注意を払って下さい

Keep your attention to connected parts are worn away.

コードNo. CODE No.	基本機種 MOTHER MODEL	基準寸法 STANDARD DIMENSION		限界 REPAIR LIMIT	型式 MODEL
	KW-089	A	44	43.98	KW-1600P
		B	—	0.03	
	KW-141	A	56	55.98	KW-2000P
		B	—	0.03	
	KW-201	A	60	59.98	KW-2500P
		B	—	0.03	
	N-280	A	76	75.98	KW-2800P
		B	—	0.03	
	KW-203	A	76	75.98	KW-3800G
		B	—	0.03	KW-3800P
	KW-329	A	91	90.98	KW-4500G
		B	—	0.03	KW-4500P
	KW-321	A	100	99.97	KW-5000G
		B	—	0.03	

(単位: mm)

The unit size by mm:



(株) 空 研 製品保守基準
 KUKEN Co., Ltd. Repair Limits
 インパクトレンチ (ブレード)
 IMPACT WRENCH (BLADE)

制定日

1998/9/30

改訂日

N型 (N-TYPE)

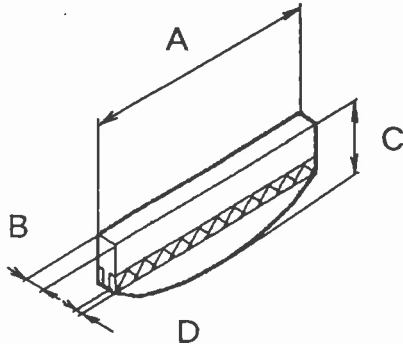

NOTE

1.よく洗浄して注意深く確認してください。

Make sure that any deformation is not observed.

コードNo. CODE No.	基本機種 MOTHER MODEL	基準寸法 STANDARD DIMENSION		限界 REPAIR LIMIT	型式 MODEL
	KW-089	A	40	39.85	KW-1600P
		B	2.5	2.0	
		C	11	10.3	
		D	—	0.1	
	N-200	A	42	41.85	KW-2000P
		B	3	2.5	
		C	13.1	12.6	
		D	—	0.1	
	N-250	A	52	51.85	KW-2500P
		B	4	3.5	
		C	13	12.5	
		D	—	0.1	
	N-280	A	57	56.70	KW-2800P
		B	4	3.5	
		C	18.7	18.2	
		D	—	0.1	
	N-380	A	57	56.80	KW-3800G
		B	4	3.5	KW-3800P
		C	18.7	18.2	
		D	—	0.1	
	N-450	A	55	54.80	KW-4500G
		B	5	4.5	KW-4500P
		C	19.6	19.1	
		D	—	0.1	
	N-501	A	75	74.80	KW-5000G
		B	5	4.5	
		C	22.5	22	
		D	—	0.1	

(単位 : mm)

The unit size by mm.



(株) 空研 製品保守基準
 KUKEN Co., Ltd. Repair Limits
 インパクトレンチ (下エンドプレート)
 IMPACT WRENCH (FRONT PLATE)

制定日

1998/9/30

改訂日

N型 (N-TYPE)

NOTE

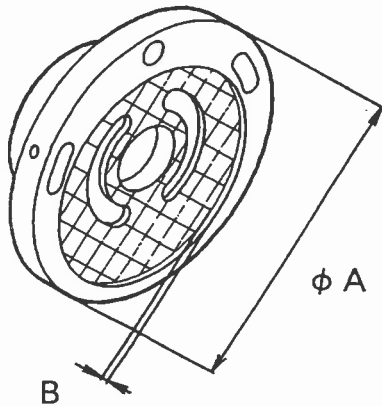

1.よく洗浄して注意深く確認して下さい

Make sure that any deformation is not observed.

2. B寸法が0.03mmを越えた場合、上下エンドプレートを交換して下さい

Please replace the front & rear plate, in case of total abrasion at "B" are more than 0.03mm.

3. 接触する部品の摩耗にも注意を払って下さい。

Keep your attention to connected parts are worn away.

コードNo. CODE No.	基本機種 MOTHER MODEL	基準寸法 STANDARD DIMENSION		限界 REPAIR LIMIT	型式 MODEL
	N-160	A	44	43.985	KW-1600P
		B	—	0.03	
	N-200	A	56	55.985	KW-2000P
		B	—	0.03	
	N-250	A	60	59.985	KW-2500P
		B	—	0.03	
	N-280	A	76	75.985	KW-2800P
		B	—	0.03	
	N-380	A	76	75.985	KW-3800G
		B	—	0.03	KW-3800P
	N-450	A	91	90.985	KW-4500G
		B	—	0.03	KW-4500P
	N-501	A	100	99.985	KW-5000G
		B	—	0.03	

(単位 : mm)

The unit size by mm.



(株) 空研 製品保守基準
KUKEN Co., Ltd. Repair Limits

制定日 1998/9/24

インパクトレンチ (D型)
IMPACT WRENCH (D-TYPE)

改訂日

指定寸法が限界を越えた場合、摩耗パーツは交換して下さい

Please replace the parts, in case of the worn size are more than limits.

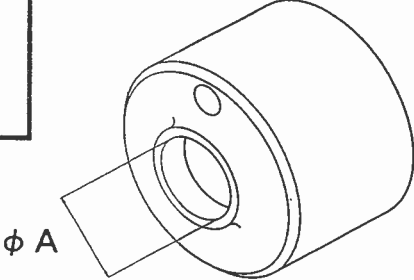
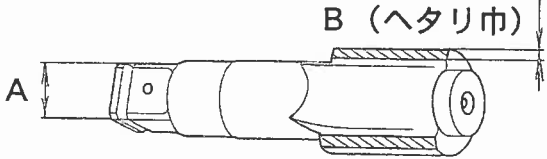
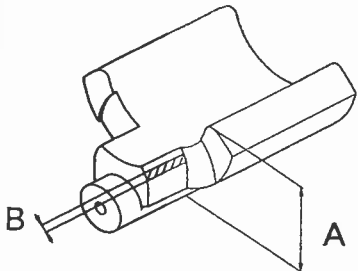
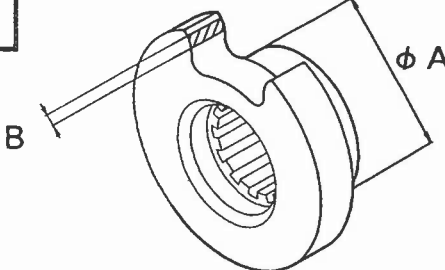
		KW-385G	KW-420G	
ハンマホイール Impact cage		基準 Standard	36	40
		限界 Limit	36.15	40.15
クラッチシャック Anvil		基準 Standard	25.4	25.4
		限界 Limit	25.15	25.15
		基準 Standard	0	0
		限界 Limit	2.0	2.0
ドッグ Hammer		基準 Standard	31.2	35.8
		限界 Limit	31.0	35.55
		基準 Standard	0	0
		限界 Limit	4.0	4.0
カム Cam		基準 Standard	36	40
		限界 Limit	35.90	39.90
		基準 Standard	0	0
		限界 Limit	4.0	4.0

よく洗浄して注意深く確認して下さい

Make sure that any deformation is not observed.

(単位: mm)

The unit size by mm.

接触する部品の摩耗にも注意を払って下さい

Keep your attention to connected parts are worn away.



(株) 空 研 製品保守基準
KUKEN Co., Ltd. Repair Limits

制定日 1998/9/24

インパクトレンチ (D型)
IMPACT WRENCH (D-TYPE)

改訂日

指定寸法が限界を越えた場合、摩耗パーツは交換して下さい

Please replace the parts, in case of the worn size are more than limits.

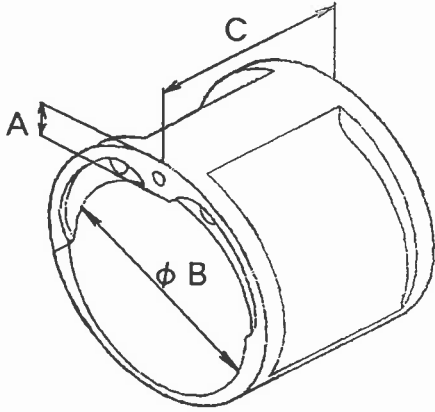
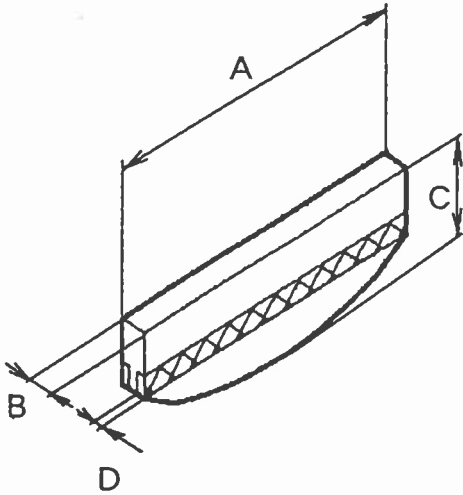
		KW-385G	KW-420G	
シリンダ Cylinder 	A	基準 Standard	14.5	16.5
		限界 Limit	14.480	16.480
	B	基準 Standard	72.8	80
		限界 Limit	—	—
	C	基準 Standard	55	65
		限界 Limit	54.990	64.990
ブレード Rotor Blade 	A	基準 Standard	55	65
		限界 Limit	54.80	64.80
	B	基準 Standard	5	5
		限界 Limit	4.5	4.5
	C	基準 Standard	21	24
		限界 Limit	20.5	23.5
	D	基準 Standard	0	0
		限界 Limit	0.1	0.1

よく洗浄して注意深く確認して下さい

Make sure that any deformation is not observed.

(単位 : mm)

The unit size by mm.

接触する部品の摩耗にも注意を払って下さい

Keep your attention to connected parts are worn away.